

# CARDEV®

## ATU

### Automatic Coolant Top Up Unit

- Automatically maintains correct fluid level
- Fail safe valve
- Self-monitoring
- Universal installation
- Low maintenance



VOLTAGE OPTIONS



COMPRESSED AIR  
SUPPLY REQUIRED

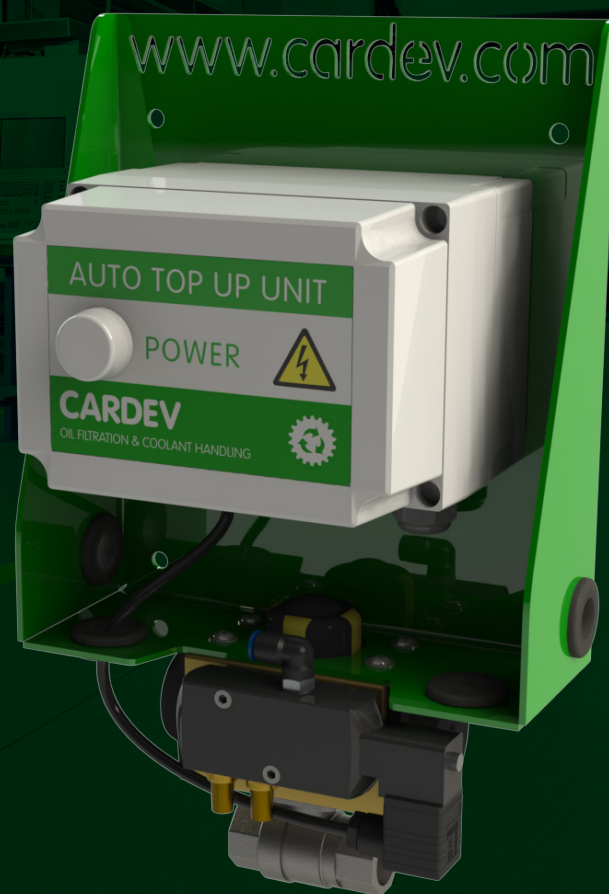

# Dimensions

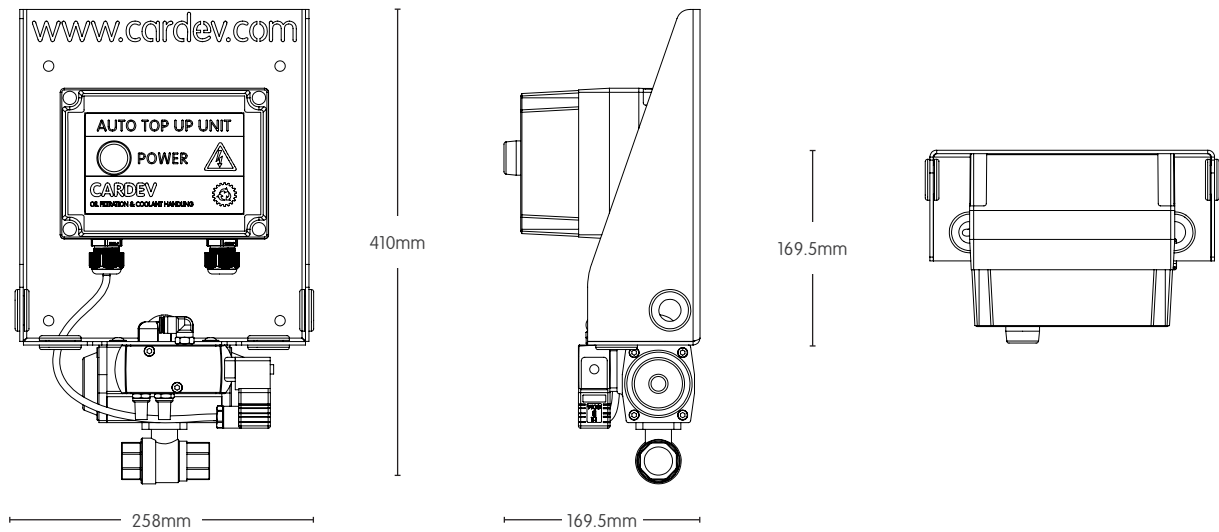

## Results

- Reduced machine downtime
- Reduced coolant consumption
- Health and Safety benefits – no manual top up
- Increased productivity and profitability

## Features

- Delivers maximum benefit when used in conjunction with CARDEV coolant mixing equipment
- Unattended operation
- Flexible installation to suit any machine
- Compact design



Recommended Installation	Services Required	Noise Level (dB)	Dimensions (mm)			Weight (kg)	Connections	
			H	W	L		Inlet	Outlet
Installed to tank, sump or reservoir and fluid source for automated level control.	230V single phase supply within 2m. Compressed air regulated at 5-7 Bar	69	410	258	169.5	6	3/4" BSP 'G' (ft)	3/4" BSP 'G' (ft)

**ETL FluidExperts**  

ETL Fluid Experts Ltd  
 Grimbald Crag Road, Knaresborough  
 North Yorkshire, HG5 8PY

T +44 (0)1423 522911 E sales@etlfe.com

[www.etlfluidexperts.com](http://www.etlfluidexperts.com)