

CARDEV 

PRODUCT DATASHEET

1S

PORTABLE OFFLINE FILTRATION SYSTEM



Dimensions

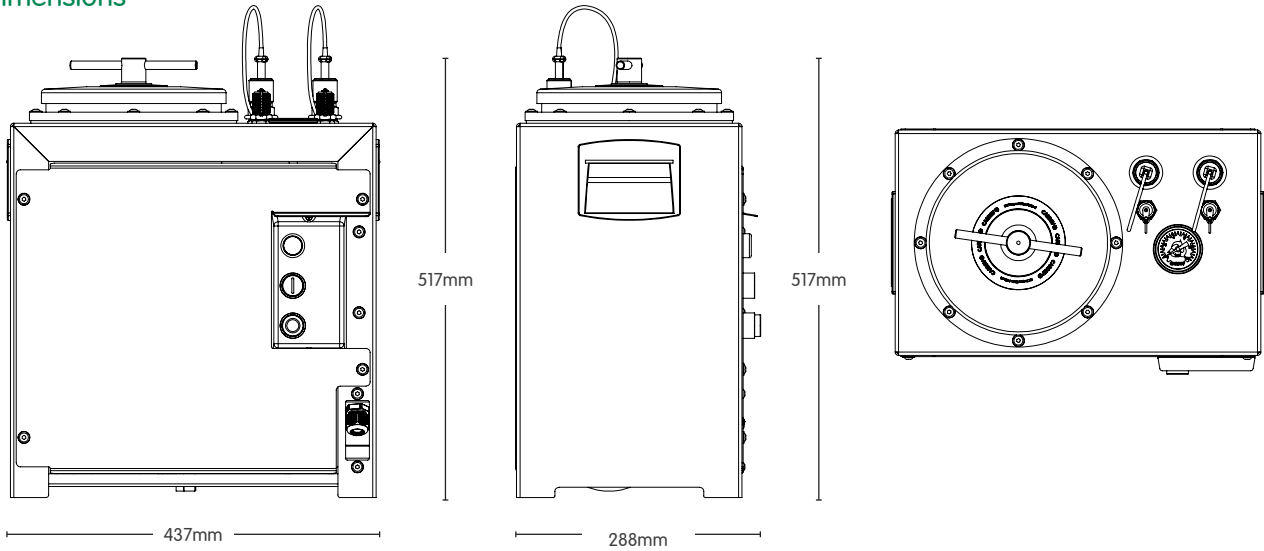

Features

- Simple controls
- Over-pressure protection
- Low pressure cutoff
- Integrated sample points – allows connection to particle monitors / oil sampling

Benefits

System benefits include:

- Removes varnish & microparticles (down to less than 1 micron)
- Removes free and dissolved water contamination
- Increases system reliability
- Prevents system corrosion
- Reduces component wear
- Extends oil life and generates CO₂ savings
- Reduces operating costs

Application Examples

Suitable for the following Industrial applications:

- Power generation
- Plastic moulding
- Cement Industry
- Manufacturing plants
- Service workshops

Max operating Temp	IP Rating	Flow Rate (l/h)**	Voltage	Current Draw	Dimensions (mm)		Weight (kg)	Filter Element Type	Retention Capacity (per set)	
60°C	IP55	140	110V	≤ 3.5 Amps	H		31	Standard fit: 1 x SDFC (oil based fluids)	≤ 2.5 Dirt (kg)	≤ 0.78 Litres of water
					517					
			230V	≤ 2.0 Amps	W	L				
					437	288				

Note: Flow rates, oil cleanliness levels and moisture removal results are based on ISO VG 46 Mineral Oil @ 40°C

ETL Fluid Experts

ETL Fluid Experts Ltd
 Grimbald Crag Road, Knaresborough
 North Yorkshire, HG5 8PY

T +44 (0)1423 522911 E sales@etlfe.com

www.etlfluidexperts.com