

CARDEV® 

4S-BS

STATIC OFFLINE FILTER SYSTEM

PRODUCT DATASHEET

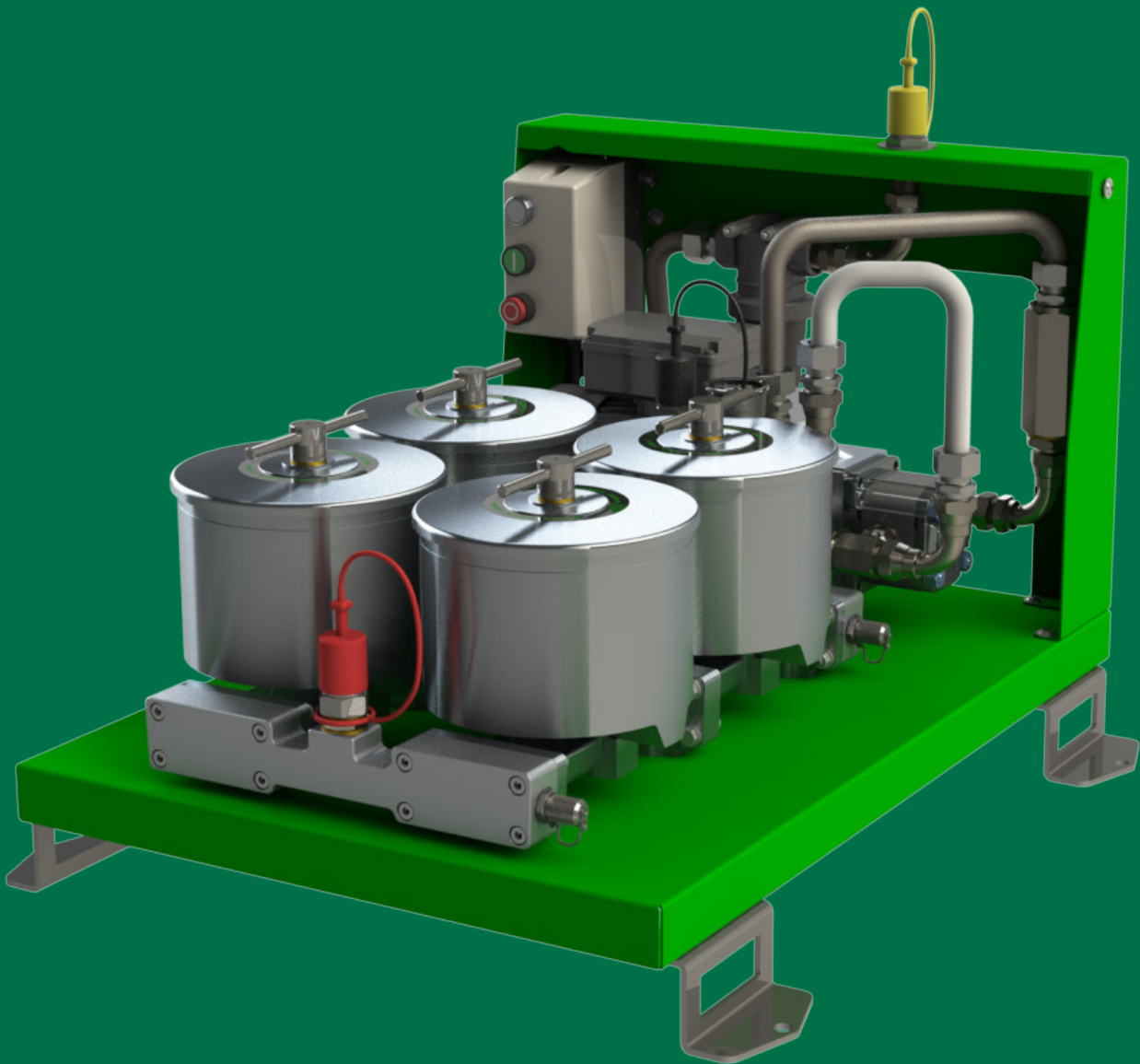

DIMENSIONS

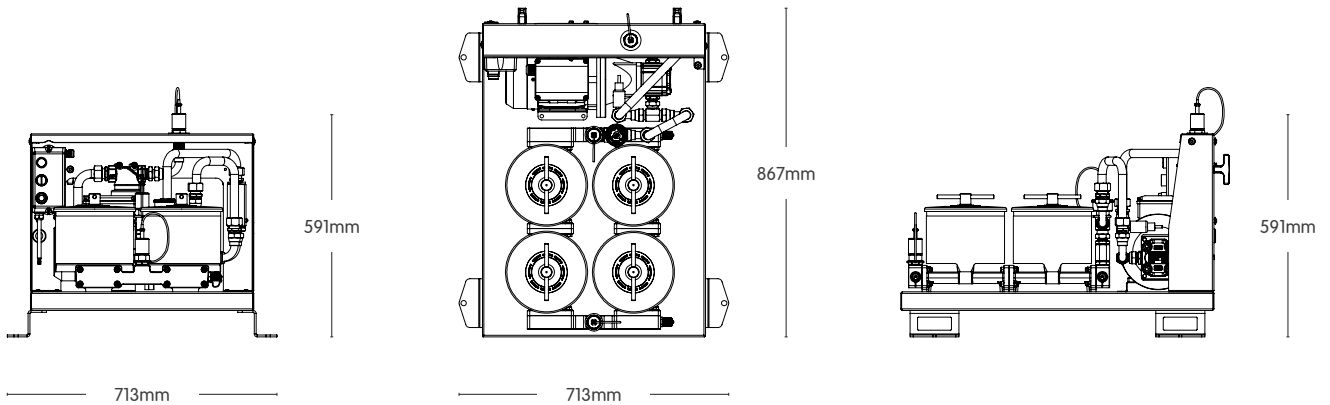

FEATURES

Include:

- Automatic low pressure cut-off
- Integrated sample points

BENEFITS

System benefits include:

- Removes microparticles
- Removes free and dissolved water contamination
- Increases system reliability
- Prevents system corrosion
- Reduces component wear
- Extends oil life and generates CO₂ saving
- Reduces operating costs

APPLICATION EXAMPLES

Suitable for the following Industrial applications:

- Earth moving machines
- Forestry equipment
- Mobile cranes
- Drilling/piling equipment
- Static hydraulic systems

Max Op Temp	IP Rating	Flow Rate (l/h)	Pump Suction Lift	Voltage	Current Draw	Power	Dimensions (mm)		Weight (kg)	Filter Element Type	Retention Capacity (per set)	
							H	W			≤ 10 kg Dirt	≤ 3.12 Litres of water
60°C	IP55	500	Self-priming to 5.5 metres	230V	5 Amps	0.55kW	591	713	95	Standard fit: 4 x SDFC		
						L						
						869						

Note: Flow rates, oil cleanliness levels and moisture removal results are based on ISO VG 46 Mineral Oil @ 40°C

ETL Fluid Experts[®]

ETL Fluid Experts Ltd
Grimbald Crag Road, Knaresborough
North Yorkshire, HG5 8PY

T +44 (0)1423 522911
E sales@etlfe.com

www.etlfluidexperts.com