

6S

MOBILE OFFLINE FILTER SYSTEM

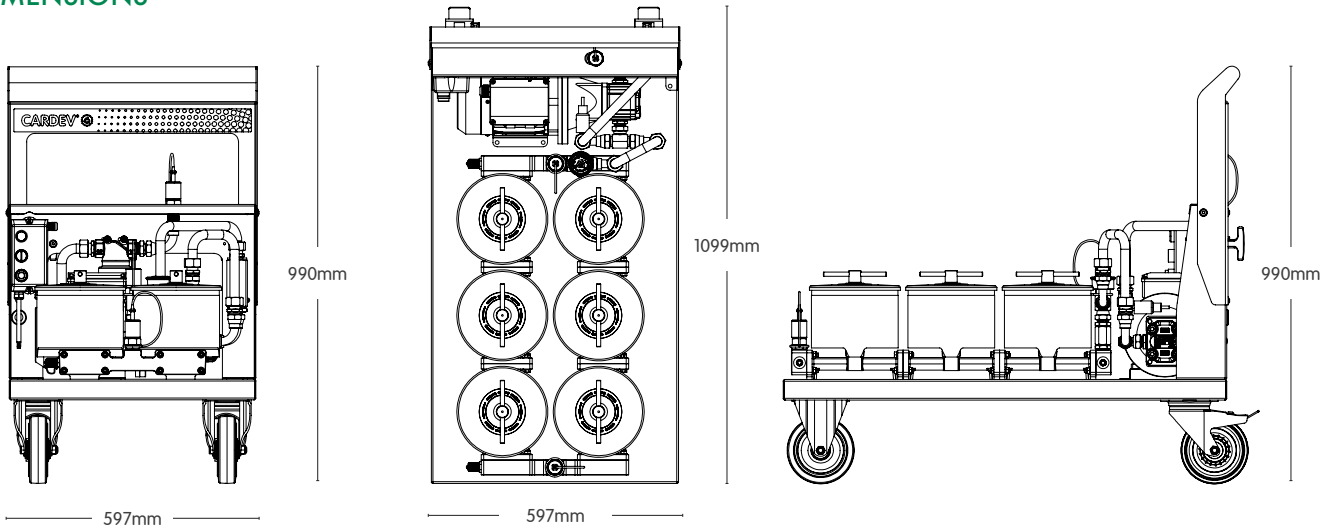

DIMENSIONS



FEATURES

- Automatic low pressure cut-off
- Integrated sample points

BENEFITS

- Removes microparticles
- Removes free and dissolved water contamination
- Increases system reliability
- Prevents system corrosion
- Reduces component wear
- Extends oil life and generates CO₂ saving
- Reduces operating costs

APPLICATION EXAMPLES

Suitable for the following Industrial applications:

- Earth moving machines
- Forestry equipment
- Mobile cranes
- Drilling/piling equipment
- Static hydraulic systems

Max Op Temp	IP Rating	Flow Rate (l/h)	Pump Suction Lift	Voltage	Current Draw	Power	Dimensions (mm)		Weight (kg)	Filter Element Type	Retention Capacity (per set)	
							H	W				
60°C	IP55	500	Self-priming to 5.5 metres	230V	5 Amps	0.55kW	990	597	110	Standard fit: 6 x SDFC	≤ 15 kg Dirt	≤ 4.68 Litres of water
							L					
							1099					

Note: Flow rates, oil cleanliness levels and moisture removal results are based on ISO VG 46 Mineral Oil @ 40°C

ETL FluidExperts®

ETL Fluid Experts Ltd
 Grimbold Crag Road, Knaresborough
 North Yorkshire, HG5 8PY

T +44 (0)1423 522911
 E sales@etlfe.com

www.etlfluidexperts.com

V01-16-05-23-GB

The specification and photography is for reference only and may be subject to change.
 © ETL Fluid Experts Ltd. All rights reserved.